

# 2 POSTS LIFT

ELECTRO HYDRAULIC

## [OSA·NSA SERIES]

CAPACITY 3,500kg



Long warranty model  
Industry leading warranty (Not including consumable parts)



Long selling series with superior column strength



### Outstanding Feature



#### SUPERIOR COLUMN STRENGTH

Hot rolled channel made especially for Bishamon forms on the basis of the load bearing structure for maximum strength.

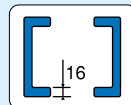

### Key Features



**FLOW CONTROL VALVE**  
Ensuring smooth lowering of any vehicle.  
It also makes the operation lever lighter.



**SAFETY HOOK**  
Safety hook features direct & positive engagement in Main Column for maximum safety against chain breakage.



**ROBUST CARRIAGE DESIGN**  
Solid steel bearings.  
Lubricated & sealed for extended service life.



**LIFT CHAIN**  
Chain is used instead of cable for maximum safety and reliability.

**SAFETY BAR AND CATCH GEAR**  
Safety bar is equipped in Sub Column for maximum safety against chain breakage.

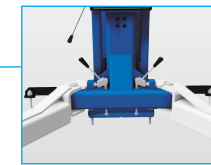

**AUTOMATIC ARM RESTRAINT WITH DUAL LEVER**  
Arms restrain automatically once lifted for maximum safety. Dual lever allows you to adjust arms individually for easy and smooth setting.



**BODY CONTACT PADS**  
Various types of Pads are available. See page 29 for more details.



**SHUT OFF VALVE**  
An automatic shut off valve is equipped in Bishamon's reliable hydraulic cylinder for maximum protection against hydraulic failure.

### Specifications

#### OSA3500N Asymmetric Type

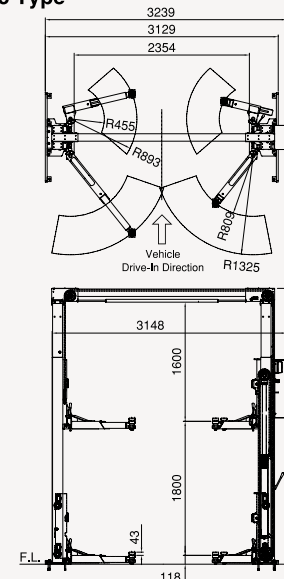

#### NSA3500N Symmetric Type

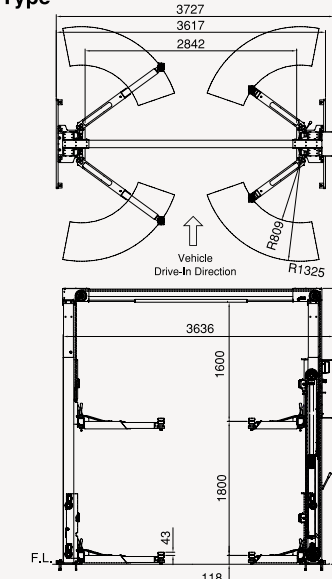

#### STANDARD POST OSA3500N / NSA3500N

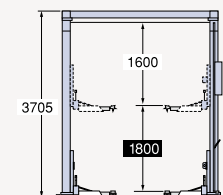

#### HIGH POST OSA3500NH / NSA3500NH

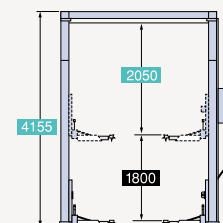

Model No.	OSA3500N	NSA3500N	OSA3500NH	NSA3500NH
Capacity	3,500kg			
Vertical Travel	1,800mm			
Control	Lever type			
Power	3 phase			
Motor	1.5kW 4P 10 min. rating			
Lifting Time (Approx)	60Hz	59 sec.		
	50Hz	70 sec.		
Oil Volume	8L (ISO VG32)			